

FIRST DEGREE FITNESS  
*Fluid* INNOVATION

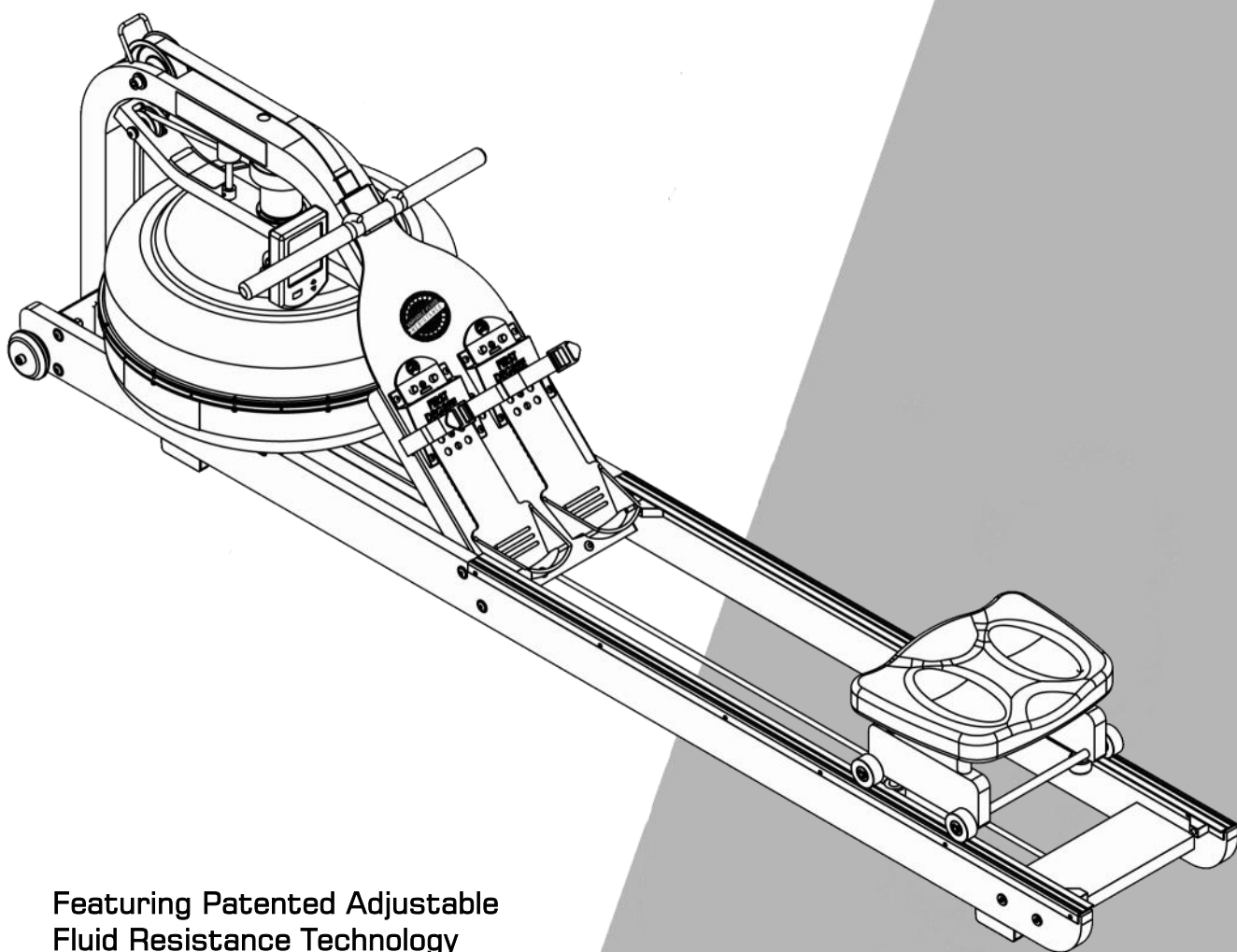

# » USER GUIDE

## APOLLO AR



Featuring Patented Adjustable  
Fluid Resistance Technology

REGISTER YOUR PRODUCT AT [WWW.FIRSTDEGREEFITNESS.COM/SUPPORT](http://WWW.FIRSTDEGREEFITNESS.COM/SUPPORT)



# » Introduction

---

Congratulations on your purchase of the Apollo AR Rower.

FIRST DEGREE FITNESS is proud to present the Rower as a home use product featuring patented Adjustable Fluid Resistance.

Our solid wood frames incorporate only the highest quality American Ash which is collected using the latest technology in sustainable harvesting from renewable plantations.

Note that slight variations of colour are normal and part of Mother nature's artistry. The wood grain patterns and subtle hues of each Rower makes every unit highly individual and designed to compliment any environment.

Follow all instructions carefully for correct assembly, tank filling, water treatment, service and safety.

Access to our world-wide distributor and service network is available at [www.firstdegreefitness.com](http://www.firstdegreefitness.com)

Check contents of Box 1 and 2 to assure all parts are present and correct prior to assembly.

## Training With The Apollo AR Rower

1. As with any piece of fitness equipment, consult a physician before beginning your Rower exercise program.
2. Follow instructions provided in this manual for correct foot position and basic rowing techniques.
3. For more detailed rowing techniques, please refer to our international website at [www.firstdegreefitness.com](http://www.firstdegreefitness.com)

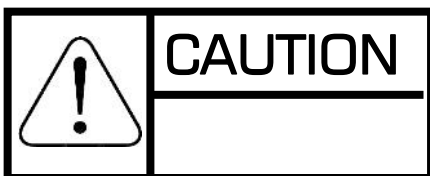

1. Keep hands and fingers away from moving parts, as indicated in this manual.
2. The Rower can stand vertically for storage. Make sure a secure location is chosen, such as the corner of a room or against a wall on an even, secure surface.

**Note:** If the storage area is not level, an additional fixture is required (sold separately) to keep the Rower stable with vertical storage position.

# » Contents

---

Safety .....	5
Assembly .....	7
Rower Box 1 & 2 Contents.....	8
Assembly Instructions.....	9
Operation Instructions.....	12
Computer Operation.....	16
Using the FIRST DEGREE FITNESS USB Interface .....	17
Detaching the Rower Belt .....	18
Reattaching the Rower Belt.....	19
Maintenance .....	20
Troubleshooting .....	21
Optional Fixture Installation .....	22
Product Exploded Diagram .....	23
International Warranty .....	26

## Safety Information

- Before using this product, it is essential to read this ENTIRE operation manual and ALL instructions. The Rower is intended for use solely in the manner described in this manual.
- UNDERSTANDING EACH AND EVERY WARNING TO THE FULLEST IS IMPORTANT
- As with any piece of fitness equipment, consult a physician before beginning your Rower exercise program.
- Please be aware that any fitness regiment, before being undertaken, is best preceded by a physical checkup from a certified physician.
- Injuries to health may result from incorrect or excessive training.
-  **WARNING** Heart rate monitoring systems may be inaccurate. Over exercise may result in serious injury or death. If you feel faint, stop exercising immediately.
- Stop the machine immediately if any signs of excessive wearing is present on the belts, pulleys and bungee cords. Do not use unit until said parts are repaired or replaced.
- Do not allow children unattended access to the machine.
- The Rower can stand vertically for storage. When doing so, please follow the instructions given in the manual.
- Please keep hands away from moving parts, as indicated by the warning label on the mainframe of your machine.
- If any of the adjustment devices are left projecting, they could interfere with the user's movement.
- Do not store in freezing conditions with water in the tank as it can expand and crack the components.

## Installation

- Place on a stable, flat surface in a horizontal position during use for maximum stability.
- Check all belts, pulleys and bungee cords regularly for signs of wear, and replace if needed.
- Check regularly and follow all instructions for maintenance as specified in this manual.
- Replace immediately any defective parts and do not operate unit until all repairs are complete.





## Proper Usage

- Do not use any equipment in any way other than designed or intended by the manufacturer. It is imperative that FIRST DEGREE FITNESS equipment is used properly to avoid injury.
- Injuries may result if exercising improperly or excessively. It is recommended that all individuals consult a physician prior to commencing an exercise program. If at any time during exercise you feel faint, dizzy or experience pain, STOP EXERCISING and consult your physician.
- Keep body parts (hands, feet, hair, etc.), clothing and jewelry away from moving parts to avoid injury.
- Follow instructions provided in this manual for correct foot position and basic rowing techniques.
- For more detailed rowing techniques, please refer to our International website [www.firstdegreefitness.com](http://www.firstdegreefitness.com)

## Inspection

- DO NOT use or permit use of any equipment that is damaged and/or has worn or broken parts. For all FIRST DEGREE FITNESS equipment use only replacement parts supplied by FIRST DEGREE FITNESS.
- Cables and belts pose an extreme liability if used when frayed. Always replace any cable or belt at first sign of wear (consult FIRST DEGREE FITNESS if uncertain).
- EQUIPMENT MAINTENANCE - Preventative maintenance is the key to smooth operating equipment as well as to keep your liability to a minimum. Equipment needs to be inspected at regular intervals.
- Ensure that any person(s) making adjustments or performing maintenance or repair of any kind is qualified to do so.
- DO NOT ATTEMPT TO USE OR REPAIR ANY ACCESSORY APPROVED FOR USE WITH THE FIRST DEGREE FITNESS EQUIPMENT WHICH APPEARS TO BE DAMAGED OR WORN.
- Check all belts, pulleys and bungee cords regularly for signs of wear, and replace if needed.
- Check regularly and follow all instructions for maintenance as specified in this manual.
- Replace immediately any defective parts and do not operate unit until all repairs are complete.

## Operating Warnings

- Keep children away from the equipment. Parents or others supervising children must provide close supervision of children if the equipment is used in the presence of children.
- Do not allow users to wear loose fitting clothing or jewelry while using equipment. It is also recommended to have users secure long hair back and up to avoid contact with moving parts.
- All bystanders must stay clear of all users, moving parts and attached accessories and components while machine is in operation.
-  **WARNING** Do not insert fingers into tank!
-  **CAUTION** After rowing exercise, please allow the unit to sit for 5 minutes before standing it up for storage.
-  **CAUTION** Do not fill past the calibration mark as indicated on the tank level sticker or water spillage can occur.
-  **WARNING** Never operate this rower without feet properly secured in Footstraps, or without the sliding portion of the Slider Footplate locked into position!

# » Assembly

## Specifications

Product Class: HC

Braking System: Speed Independent

Product Net Weight: 32.7kg(72.09lb)

Product Gross Weight: 39.5kg(87.08lb)

Minimum Safe Operating Surface Area: 333cm (131.09") x 172cm (67.71")

Dimensions: 2130mm(83.85") Length x 520mm (20.47") Width x 560mm(22.04") Height

Maximum User Weight: 150kg (330lb)

Compact Footprint: 2,130mm x 520mm or upright 520mm x 560mm

## Product Highlights

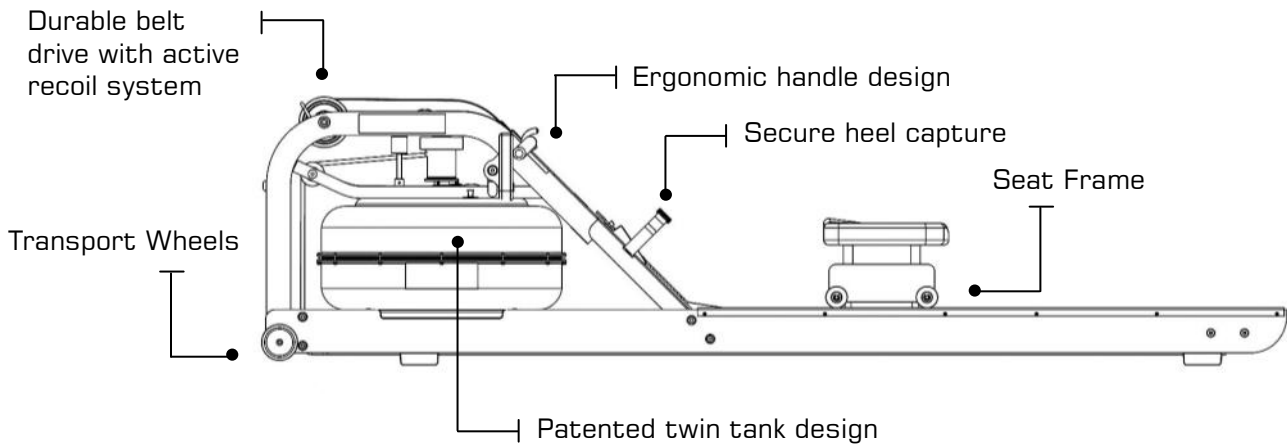

The live area shall be not less than 60cm (23.62") greater than the training area in the directions from which the equipment is accessed. The live area must also include the area for emergency dismount.

## Live area and Training area

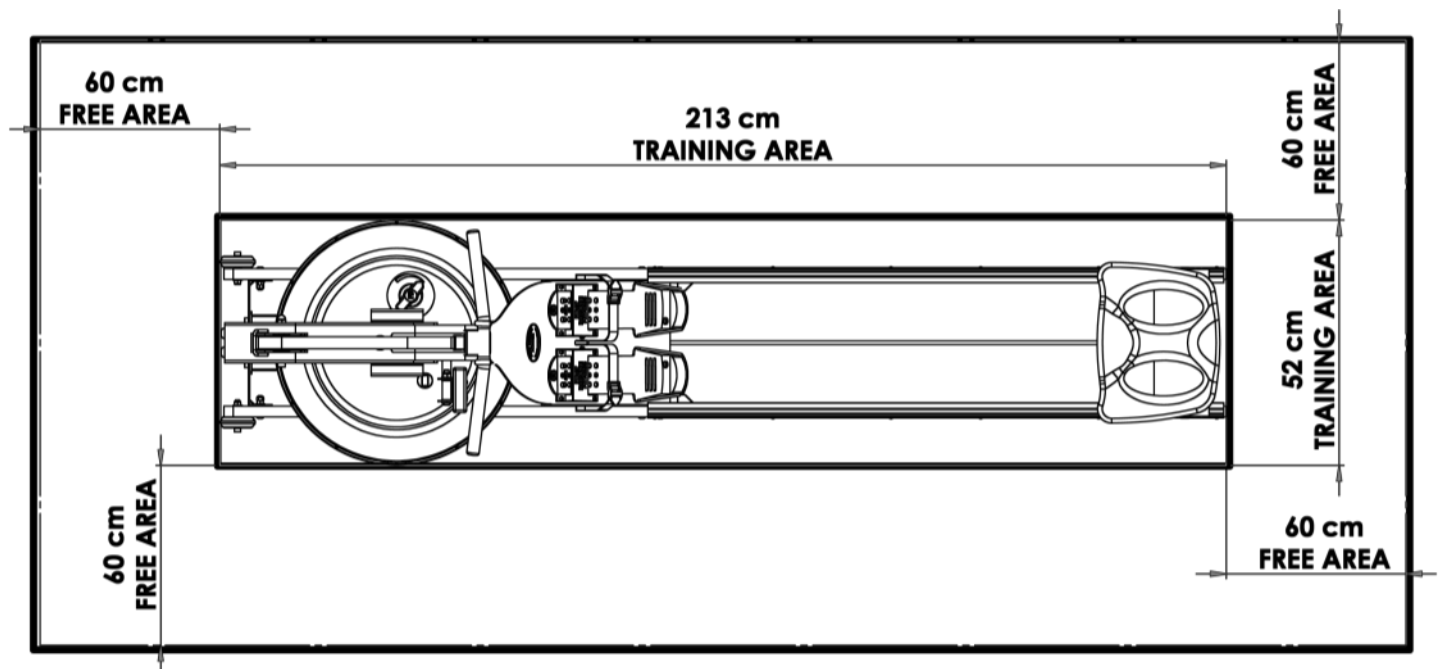

Note: Rower is not suitable for therapeutic purposes.

# » Rower Box 1 & 2 Contents

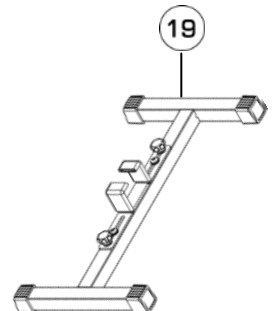
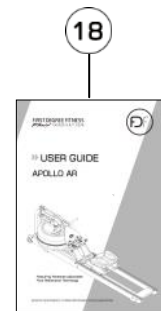
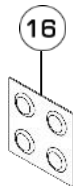
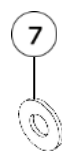
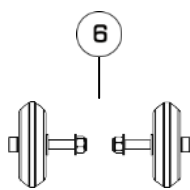
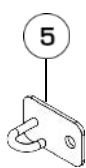
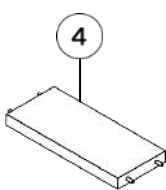
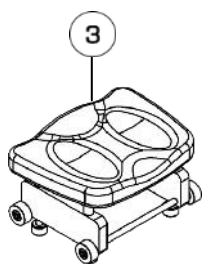
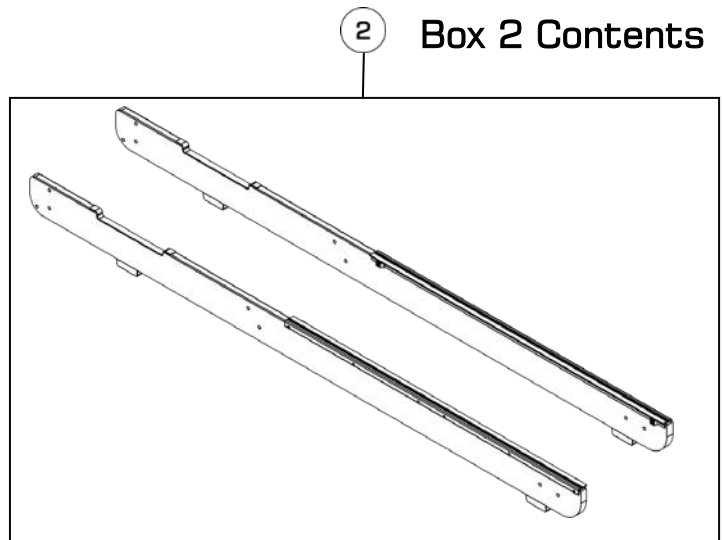
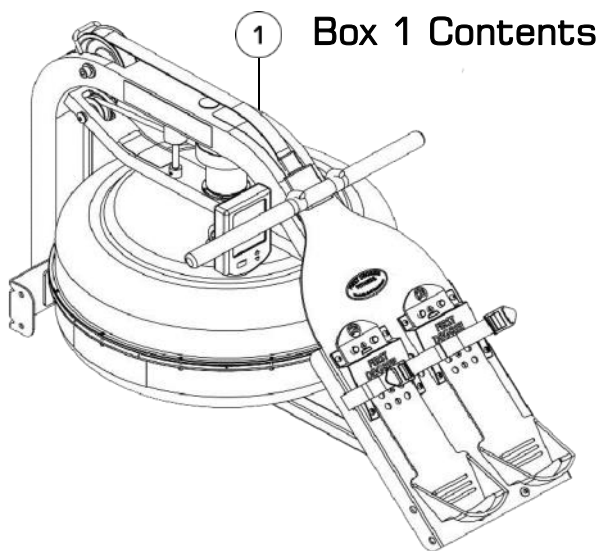

Item	Qty.	Description	Item	Qty.	Description
1	1	Mainframe	11	8	M8x45mm Bolt
2	2	Left / Right Side Rail	12	1	5mm Allen Key
3	1	Rower Seat	13	1	6mm Allen Key
4	1	Rear Brace	14	1	13mm Spanner
5	1	Bungee Hook Mount	15	2	AA Duracell Battery
6	2	Transport Wheel Assembly	16	4	Water Treatment Tablet
7	16	M8 Washer	17	1	Siphon
8	8	M8 Standard Nut	18	1	User Guide
9	8	M8 Nylock Nut	<b>Optional Equipment (Not Included)</b>		
10	4	M6x15mm Bolt	19	1	Optional Stand (not included)



# Assembly Instructions

## STEP 1

### Installing the Rear Brace and Transport Wheel Assembly to Seat Rail

#### REQUIRED

- Side Rail Left / Right [2]
- Rear Brace [4]
- Bungee Hook Mount [5]
- Transport Wheel Assembly [6]
- 4x M6x15mm Bolts [10]

#### WARNING

Rotate Rear Brace to correct orientation before assembly onto Side Rails

- a) Start with the **Rear Brace** and on the underside you will find a **Pre-installed bolt**. From the hardware kit, take the **Bungee Hook Mount** and install it onto the **Rear Brace** as shown. Note the orientation of the **Brace** and hook must be correct in order to hold the end of the **Bungee Shock Cord** as depicted by the arrow in the illustration, which points toward the front of rower.

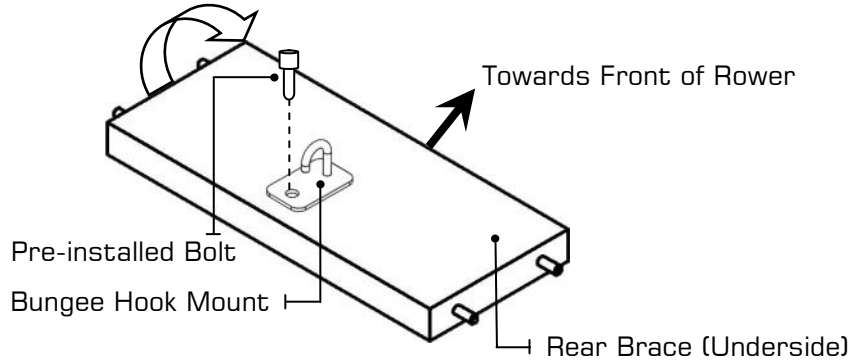

#### WARNING

Note Transport wheels must be mounted on the outside of Side Rails As shown below.

Do not over tighten the Transport Wheel Axle as it may inhibit Transport Wheel rotation.

- b) Next, connect the **Side Rail Left** and **Side Rail Right**[2] using **4x M6x15mm Bolts**[10] and **Rear Brace**[4]. **DO NOT TIGHTEN.**

Tip: Bumpstops facing inside of rail for correct assembly orientation.

- c) Once the **Rear Brace** and **Side Rails** are assembled, mount the **Transport Wheel Assembly**[6] onto the **Left/Right Side Rails**[2].

Note: One washer on outside and one washer on the inside of the side rail.

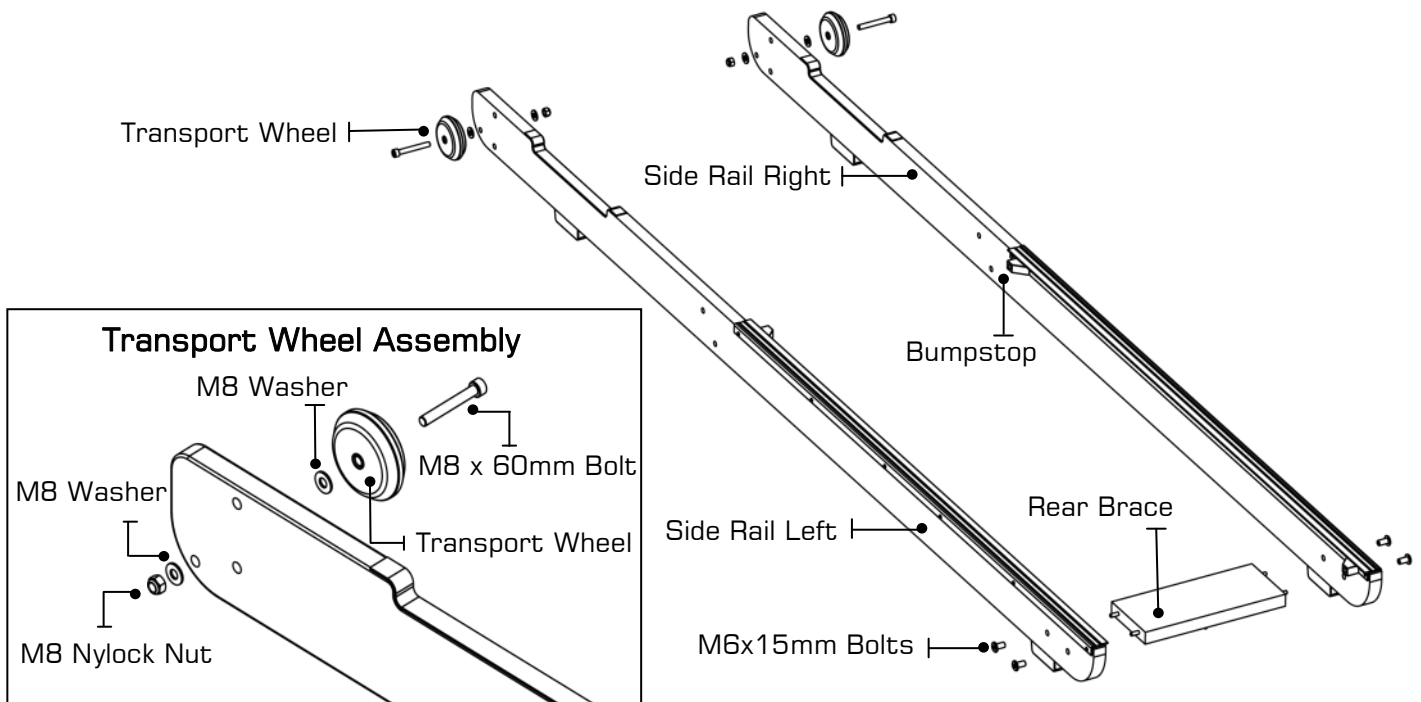

# Assembly Instructions

## STEP 2 Mounting Rower Seat and Upper Mainframe

- REQUIRED**
- Left / Right Side Rail [2]
  - Rower Seat [3]

To install the rower seat, spread the **Left/Right Side Rails**[2] slightly and drop the **Rower Seat**[3] into the track.

**Note:** Seat indentation must face rearward.

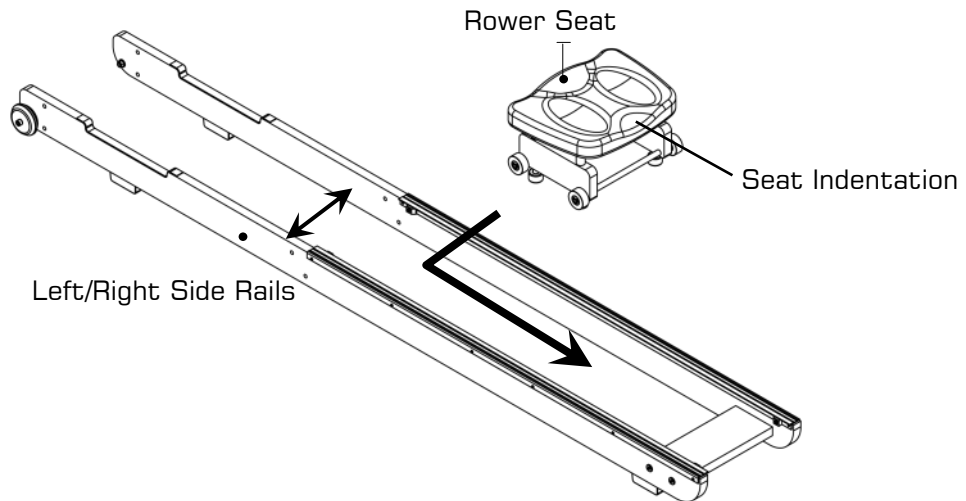

## STEP 3 Mounting Rower Seat and Upper Mainframe

- REQUIRED**
- Mainframe [1]
  - Side Rails Assembly [2]
  - 16x M8 Washers [7]
  - 8x M8 Standard Nuts [8]
  - 8x Nyloc Nuts [9]
  - 8x M8x45mm Bolts [11]

Next, install the **Mainframe**[1] onto the **Side Rail Assembly**[2] as shown. You will need **8x M8x45mm Bolts**[11], **16x M8 Washers**[7], **8x M8 Standard Nuts**[8] and **8x M8 Nyloc Nuts**[9].

Secure the front Lower Bracket first, then the Footboard but **DO NOT TIGHTEN**. You may find that the Lower Bracket Bolts can be difficult to access. You can tighten these bolts completely once the Rower is standing in the vertical position so for the moment, simply align and loosely thread lower bolts/nuts.

**CAUTION**

Nyloc nuts must be outside the standard nut and washer to properly secure assembly.

**Note:** Clean wheels and tracks weekly with a soft dry cloth in order to decrease the rate of wear on both wheels and track.

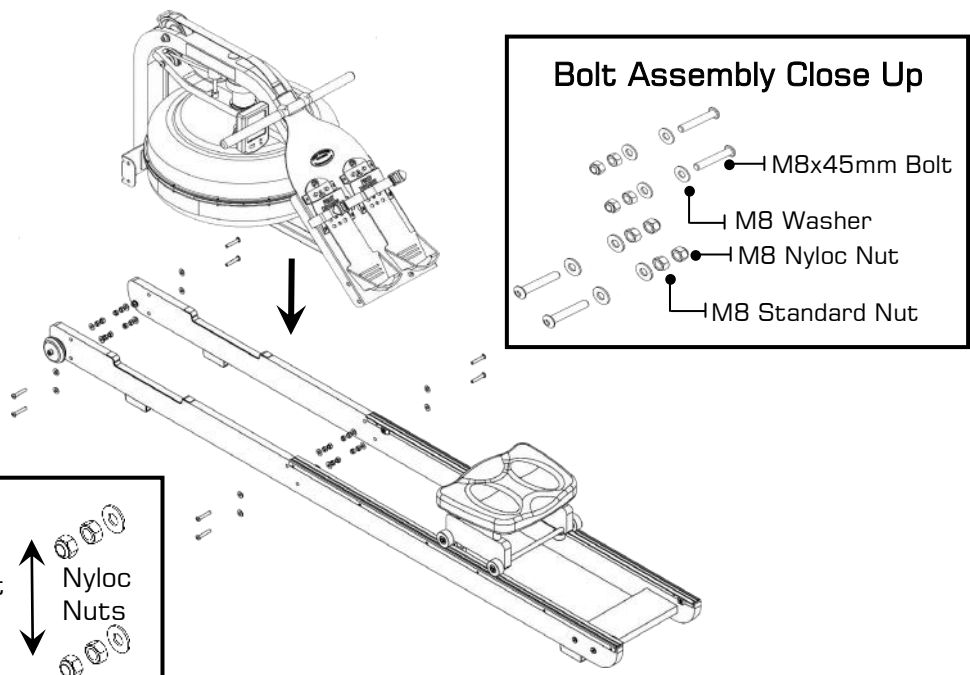

**CAUTION**

Nyloc Nuts must be outside the standard nut and washer to properly secure assembly.

Nyloc Nuts

Nyloc Nuts

# » Assembly Instructions

## STEP 4

## Completing the Rower Assembly

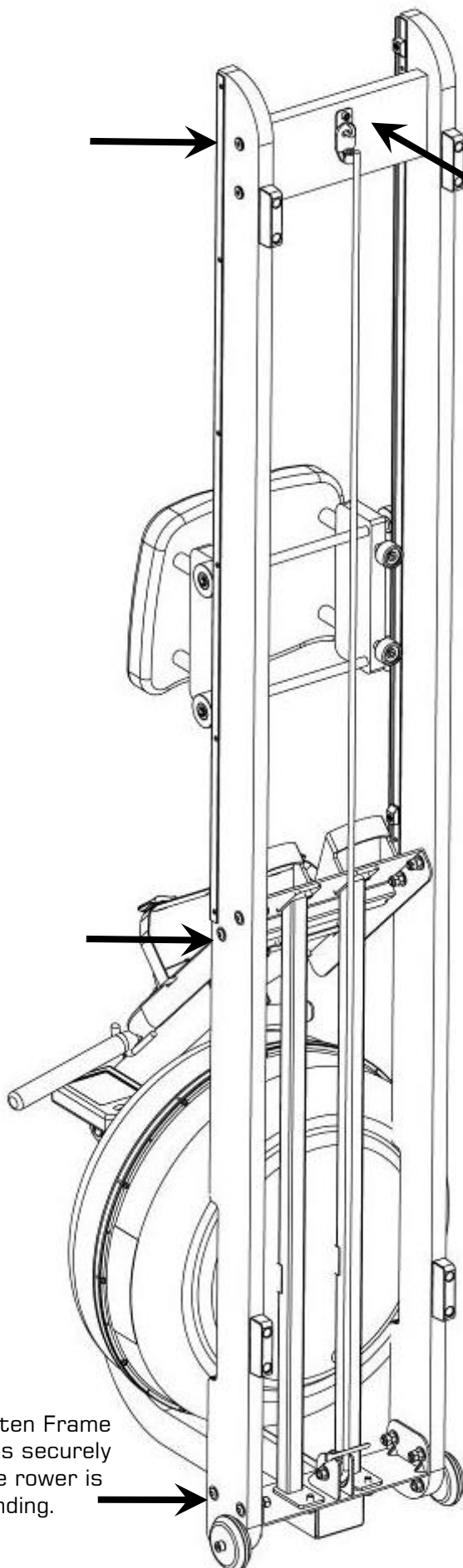

Tighten Frame Bolts securely once rower is standing.

Pull Bungee Cord and Hook Bungee End onto the **Bungee Hook Mount[5]** as shown.



Do not cut Bungee tie wrap before Bungee cord is attached to rear of rower as shown here.

Once the Bungee Cord is attached to the Rear Brace, tighten the bolts holding the Footboard, the Mainframe to Side Rail Bolts as they are easier to access from the vertical position.

Lower the Rower back to the Horizontal position and test for proper bungee recoil.

Check Seat Rollers/Runners for dirt or debris before sitting on the rower seat. Small objects captured between the seat rollers and runners can damage the wheels or running surface. Check runners for debris prior to each use and clean regularly.

Note: The Rower Frame Bolts require periodic checking for tightness. Do this at the end of the first month of use and again after every 12 months

Choose a suitable location when standing the product for storage.

The Rower frame can be polished with any high grade furniture polish to further highlight the rich luster of the wood finish.

Install supplied 2x AA Duracell battery and check computer function. Details regarding can be found in the Computer section of this manual.

Choose a flat, level surface on which to use your Rower, to avoid rocking and potential premature wear.

# » Operation Instructions

## » Adjustable Resistance (AR) Tank

The Adjustable Resistance (AR) Tank, developed and patented by FIRST DEGREE FITNESS, offers a true multi-level experience. Water is moved between the "storage" and "active" chambers of the AR Tank. Your new Rowing Ergometer can adapt - at the turn of a dial - to the resistance preferred by each user in the home environment.

### Getting Started

To achieve minimum resistance, select "MIN" on the tank adjuster. **It takes 10 strokes to fill the central (storage) tank, leaving a minimal amount of water in the outer (active) tank. This process is always required if minimum resistance is desired.** Row hard at a steady pace (20 to 25 strokes per minute [SPM]) and put some effort into the stroke, ensuring that good form is maintained. You can make adjustments to the resistance level while you row. Your Rowing Ergometer will adapt almost instantly to increases in resistance but will take up to 10 strokes to reduce the effort required, as the central (storage) tank fills up.

### Developing Your Routine

Once you have found a level that gives you the exercise required, changes can be made to SPM and to stroke intensity to further vary your energy input. Interval training is used by most Rowers, where a period of low intensity is combined with short intervals of high intensity. Your FDF Rowing Ergometer allows for changes 'on the fly', to achieve multi-level resistance profiles during a single workout. For more information on exercise routines, please visit our website at [www.firstdegreefitness.com](http://www.firstdegreefitness.com)

## » Tank Filling and Water Treatment Procedures

**REQUIRED**  
Siphon [17]

**CAUTION**  
Resistance adjuster must be set to 'Max' to allow for accurate filling capacity.

**WARNING**  
Do not overfill the tank beyond the maximum indicated level of 17 liters. Refer to the tank level decal on the lower side of the tank.

- Remove rubber fill plug from the top of the tank.
  - Place a large bucket of water next to the rower. Position the **Siphon[17]** with rigid hose in the bucket, and flexible hose in the tank.
- Note:** Make sure small breather valve on siphon is closed before filling.
- Squeeze siphon to begin filling. **Important:** Do not overfill tank
  - When full, open the valve on the top of the siphon to allow excess water to escape.
  - Once filling is completed follow the water treatment schedule below, then replace the tank plug.

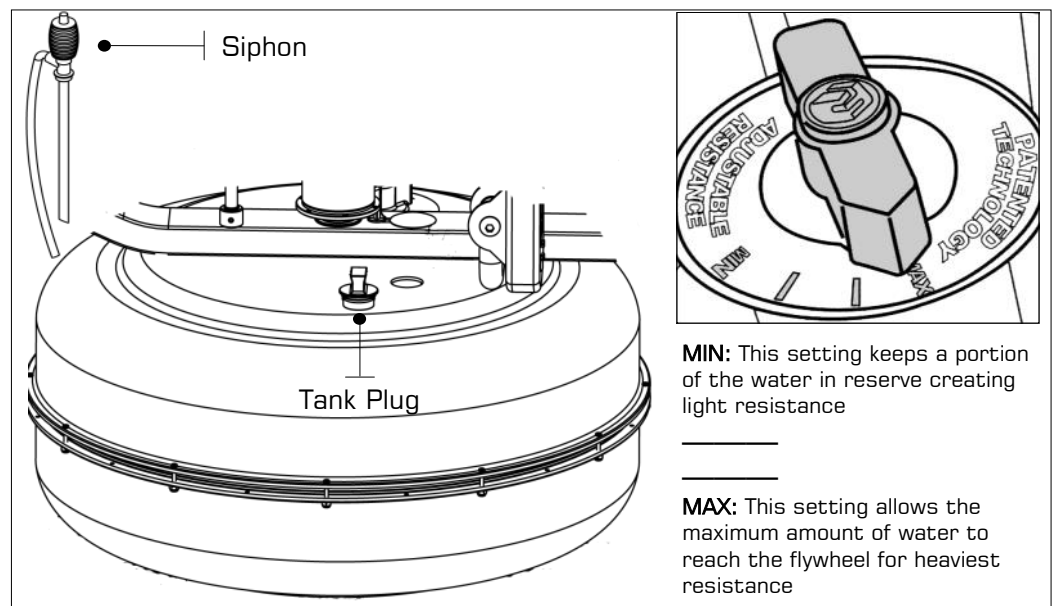

### INITIAL WATER TREATMENT

Add 1 x Water Treatment Tablet per full tank. **DO NOT, UNDER ANY CIRCUMSTANCE, USE A WATER TREATMENT TABLET OTHER THAN THOSE SUPPLIED WITH YOUR UNIT.** Your unit purchase includes 4 x Water Treatment Tablets, which is sufficient for several years of use. To purchase additional chlorine tabs, please consult your nearest regional dealer/distributor or check our website at [www.firstdegreefitness.com](http://www.firstdegreefitness.com)

## »» Operation Instructions

### »» Removing/Changing Tank Water

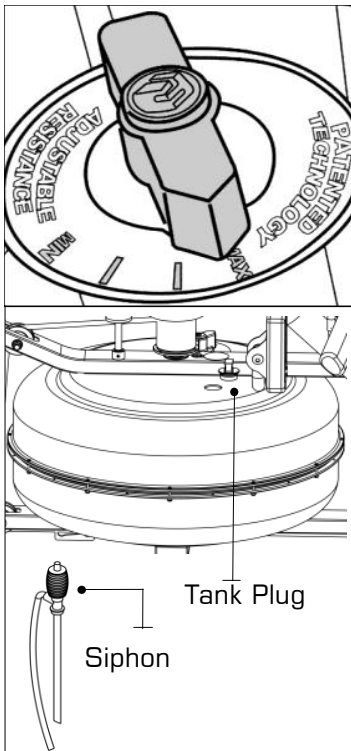

Row a minimum of ten complete strokes before commencing tank draining. Remove tank plug, insert rigid end of siphon into tank and begin draining.

- Set Adjuster handle to "MIN"
- Row at least ten strokes to fill the storage reservoir as completely as possible.
- Remove Tank Plug.
- Insert rigid end of siphon into the tank, and flexible hose into a large bucket.
- Drain tank (approx. 40% of water will remain) and then refill following directions for Tank filling as described in the Tank Filling section of this manual.

**Note:**

- ⊙ The valve on top of the siphon must be closed to allow proper drainage.
- ⊙ Water treatment will preclude the need to change tank water if the treatment schedule is maintained. Additional Water Treatment Tablet is required only when discoloration appears in the water.
- ⊙ Exposure to full sunlight reduces the life of the Water Treatment Tablets. Storing the rower away from direct sunlight will extend the time between water treatments.
- ⊙ Approximately 40% of tank water will remain. It is not possible to completely drain the A/R tank without disassembly.

### »» Long Term Water Treatment and Basic Operation

**Do not use any water treatment other than the tablets supplied with this unit.** For replacement tablets, contact your local First Degree Fitness distributor. Water treatment schedules for the FLUID ROWER will vary according to the fluid tanks exposure to sunlight, but expect 8-12 months near a bright, sunlit window and 2 years or more for a darker location. At the point of finding the water slightly cloudy, add a Water Treatment Tablet.



**CAUTION**

It is strongly recommended that a drop cloth be used under the fluid tank whenever the tank plug is opened for water treatment.

# »» Operation Instructions

## »» Start Rowing

There are six phases to completing a rowing stroke

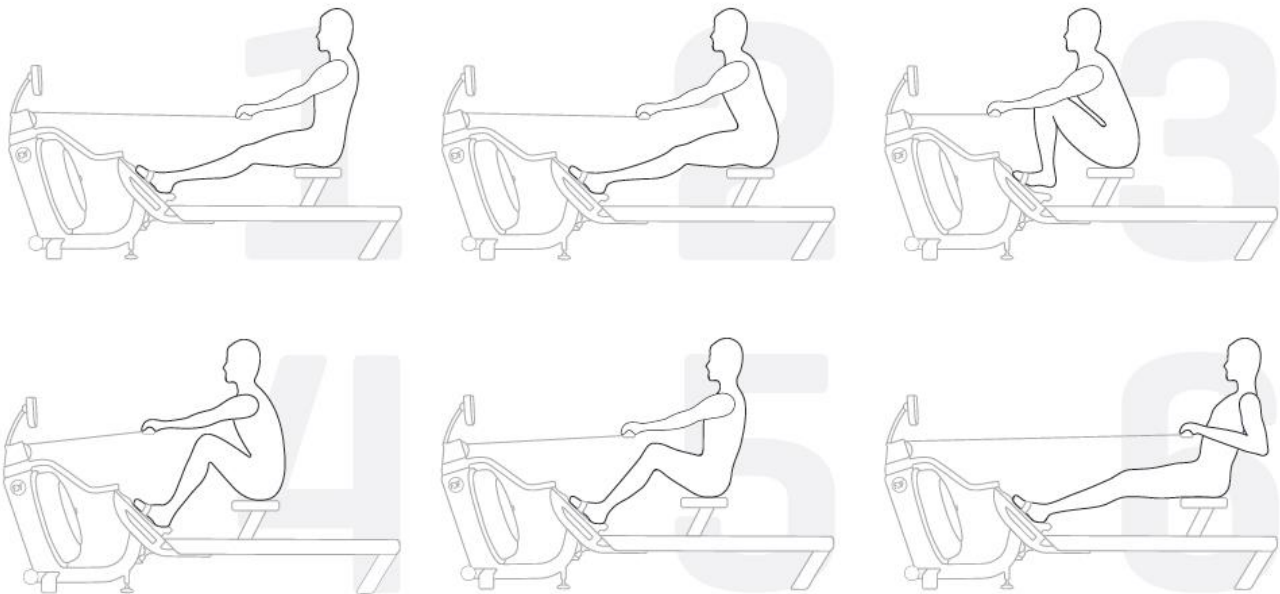

1. Sit with straight legs and back, leaning forward slightly at the hips with arms out straight and hands level with the lower ribs. Swing back.
2. Legs and back straight, leaning slightly forward from the hips, arms out in front. Lean and slide forward.

**Note:** Hands should now be around your knees, keeping legs straight.

3. Legs come forward, aiming to get the shins vertical. Back is still straight, and posture leaning slightly forward with arms still out front. Now drive hard, this is the CATCH.
4. Knees partially straightened so seat is now at mid-point of travel, back and arms still straight. Maintain the stroke.
5. Knees are nearly straight, back is still straight but now leaning slightly back from the hips. Arms straight. Now squeeze through.
6. Legs now fully extended. Back straight and leaning slightly back, now pull with the arms so they are close to the chest, forearms horizontal and elbows close in to the rib cage. This is the FINISH.

For more information on correct rowing technique and workout tips visit our website [www.firstdegreefitness.com/indoor-rowing-technique](http://www.firstdegreefitness.com/indoor-rowing-technique)



**CAUTION** Always consult a doctor before beginning an exercise program. Stop immediately if you feel faint or dizzy.

# »» Operation Instructions

## »» Adjust Footplates

The Slider Footplate accommodates most foot sizes, and is designed to keep your feet securely in place as you row.

### TO ADJUST:

Lift the top of the footplate from the mounting peg and slide vertically between 1-6 to suit your foot length. Secure by hooking the footplate back onto the mounting peg and pushing down firmly to lock it into position. Place feet on the foot plates and tighten the foot straps to ensure your feet sit firmly against the heel captures.

**Note:** The heel capture should bend to allow your foot to pivot naturally as you row.

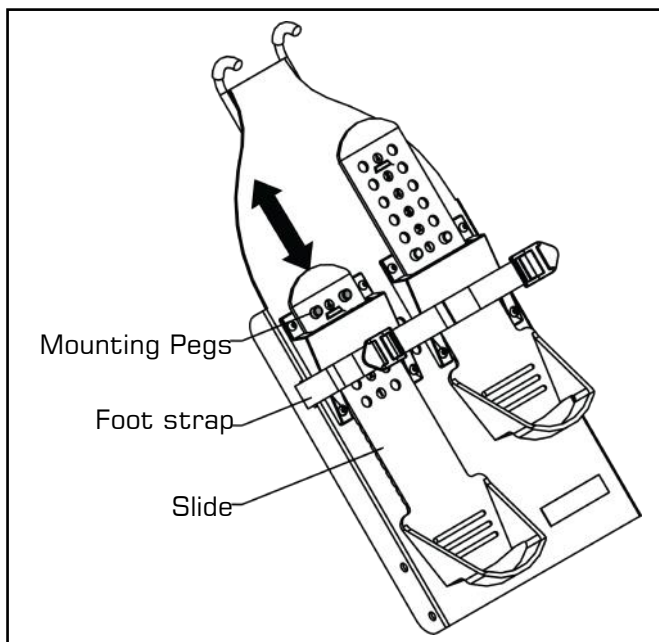

**WARNING:** Never operate this Rower without feet properly secured in Footstraps, or without the sliding portion of the Slider Footplate locked into position!

# Computer Operation

## Functions

**Auto Start:** Commence rowing to activate.

**Reset all values:** Press and hold RESET button for 3 seconds.

**Distance:** Each single press of RESET adds 100m distance, up to 1000m then adds 500m.

**Auto-Pause:** A temporary halt in exercise will result in the following:

For over 5 seconds and under 5 minutes:

- a) SPM/500METER/WATT to zero.
- b) Distance/TIME values are saved.
- c) CAL per hour defaults to Total CAL.
- d) A Resumption in exercise in less than 5 minutes will resume Distance/TIME from saved values automatically.

**Auto Power Down:** Over 5 minutes. All values revert to zero after restart.

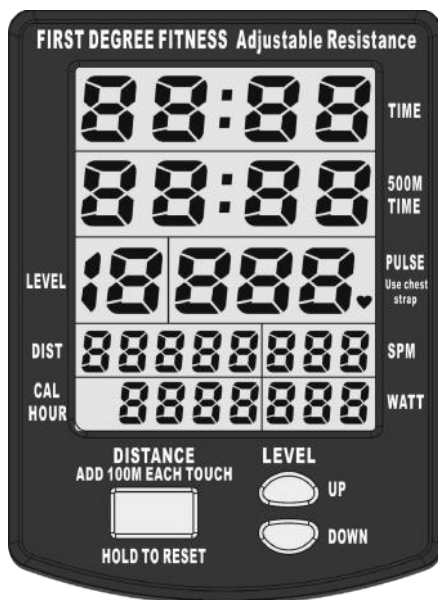

## Computer Instructions:

- **TIME:** Auto start elapsed time.
- **500M TIME:** Time to row 500 meters, updated at the completion of each stroke.
- **PULSE:** Requires optional receiver and chest strap (sold separately).
- **SPM:** Strokes per minute updated each stroke.
- **WATT:** Unit of power updated per rowing stroke.



**CAL HOUR:** Calories burned per hour at the current Watts. Shows total calories burned when exercise is stopped.

**\*ALL READINGS UPDATED EVERY 2 SECONDS**

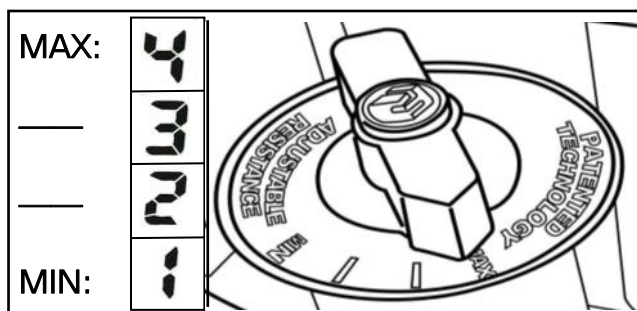

**NOTE:** Heart Rate Kit and Chest Strap is sold separately.

 <b>WARNING:</b>	Heart rate monitoring systems may be inaccurate, Over exercising may result in serious injury or death. If you feel faint stop exercising immediately!
--	--



# » Using the FIRST DEGREE FITNESS USB Interface

---

## Description:

The USB connectivity now built in to all new models of FDF Console and IPM allow you to enhance your exercise experience by connecting to your home PC or Laptop. Using FDF's own sample applications you can exercise while enjoying your favorite movies. NetAthlon 2 XF for Rowers lets you race with other Internet connected rowers in a Virtual Reality 3D environment or train solo.

## Setting Up USB connectivity

1. Connect your console to your Laptop/PC (Windows 7/8/10). Windows should automatically install the latest USB driver.
2. Alternatively, if #1 fails, download and Install the USB Device Driver (CDM2xxxx\_Setup.exe for 32 and 64 bit Windows 10/8/7/Vista/XP) from the FDF Website.
3. Download and Install the Fluid Coach software from the FDF Website (<https://firstdegreefitness.zendesk.com/hc/en-us/articles/228299348-Fluid-Coach-Version-1-3>)

Download and Install NetAthlon 2 XF for Rowers from.

<http://www.webracing.org/downloads.htm>

## Connecting Your Console

- The USB Connector is located on a flying lead at the rear of the IPM, along with the Sensor and Heart Rate Monitor Connectors.
- Connect to a Laptop or PC using a standard USB cable, you may need to wait while Windows starts the USB Device Driver.

**Note:** Please refer to computer manual where applicable or for further information refer to our website at [www.firstdegreefitness.com](http://www.firstdegreefitness.com)

## » Detaching the Rower Belt

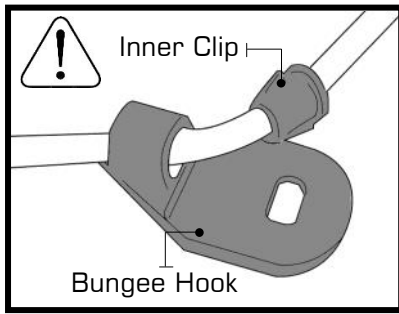

1. To detach belt, simply pull beyond the range of the normal rowing stroke until the belt detaches from the belt bungee pulley.

**Tip:** You'll hear the Velcro separating just before the belt detaches.

2. Unhook the Bungee Shock Cord from the Rear Brace. Then, push out the Inner Clip from the Bungee Hook. Pull the Bungee through the Inner Clip until free. This will allow for the Bungee Shock Cord to be threaded completely out of the Main Frame and up to the Belt Bungee Pulley where it will be re-attached once the Rower Belt is in the proper position.

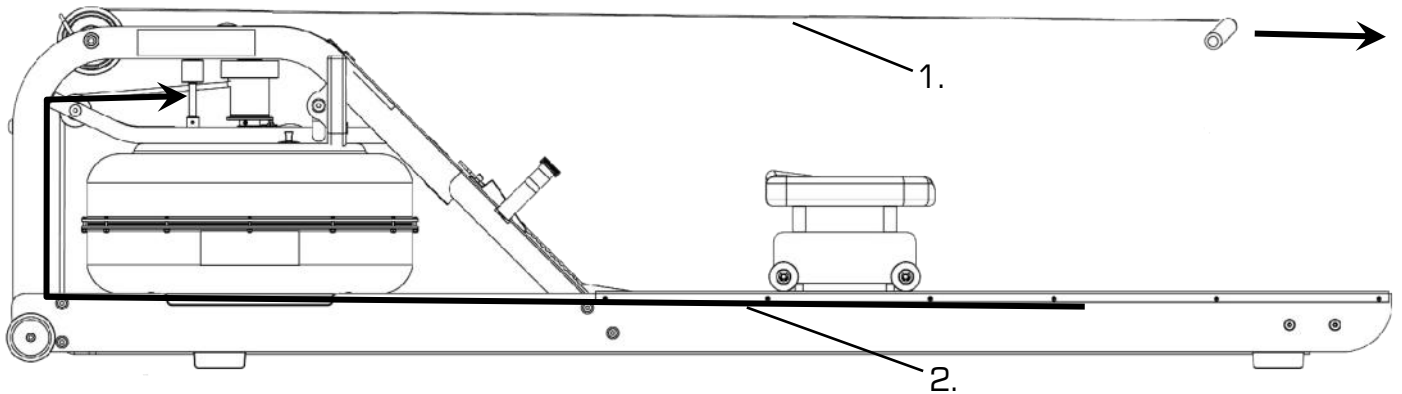

# » Reattaching the Rower Belt

## STEP 1

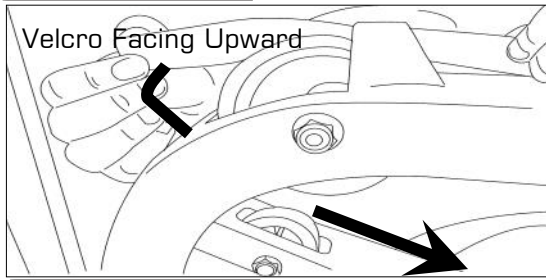

Begin reattaching the Rower Belt by threading around the Rower Belt Pulley with the Velcro side facing upward as illustrated.

## STEP 2

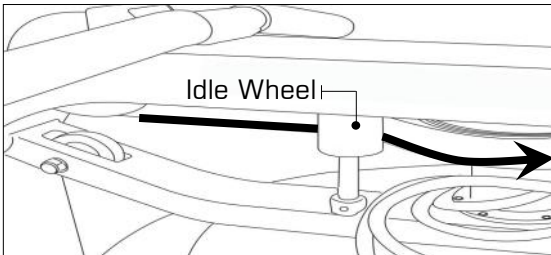

Next, thread the Belt around the Idle Wheel as shown. Once around the Idle Wheel, attach the Rower Belt to the Belt/Bungee Pulley. There is an obvious "lip" at the attachment point.

## STEP 3

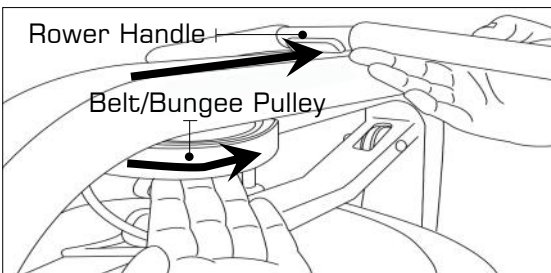

Wind the Rower Belt onto the Belt/Bungee Pulley until the Rower Handle is as it's furthest forward position.

## STEP 4

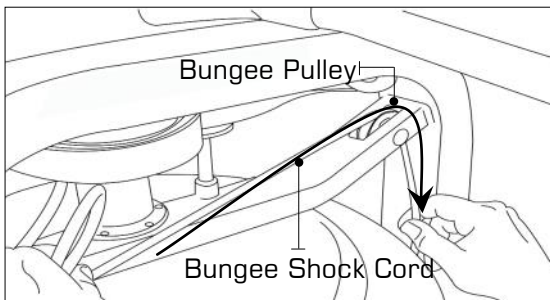

Rethread the Bungee Shock Cord (on opposite side of the Idle Wheel) back through the Bungee Pulleys and tie off at the Attachment Point.

## STEP 5

Recoil tension will decrease over time as the Bungee Shock Cord stretches. To increase recoil tension, simply push the Inner Clip out of the Bungee Hook from behind, pull the required amount of bungee through the Inner Clip and replace the Inner Clip into the Bungee Hook as shown below.

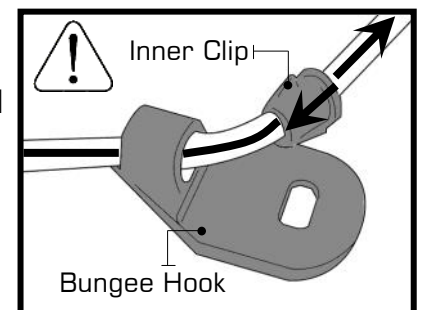

**Hint:** Before reattaching the Inner Clip/ Bungee Hook, tie a slip knot under slight tension at the lower bungee pulley. This will keep the bungee under tension while reassembling the Bungee Hook.

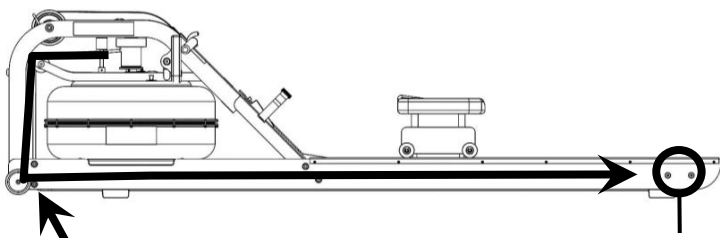

## » Maintenance

All preventive maintenance activities must be performed on a regular basis. Performing routine preventive maintenance actions can aid in providing safe, trouble-free operation of all FIRST DEGREE FITNESS equipment.

FIRST DEGREE FITNESS is not responsible for performing regular inspection and maintenance actions for your machines. Instruct all personnel in equipment inspection and maintenance actions and also in accident reporting and recording.

Item	Time Frame	Instructions	Notes
Seat and Seat Rails	Weekly	Wipe down Seat Rails with lint free cloth.	
Frame	Weekly	Wipe down Frame with lint free cloth.	
Tank and Water Treatment	12 months to 2 years	Follow instructions as specified in the "Water Treatment Procedure" section of this manual.	
Bungee Cord	Check every hundred hours for correct tension and for signs of wear.	The Bungee Cord should last for many years. If a Bungee Cord change is required, please contact your local service representative or go online at <a href="http://www.firstdegreefitness.com">www.firstdegreefitness.com</a> for further details.	
Rowing Belt	Check every hundred hours for correct tension and for signs of wear.	The Rowing Belt should provide many years of trouble free use. If a Rowing Belt change is required, please contact your local service representative or go online at <a href="http://www.firstdegreefitness.com">www.firstdegreefitness.com</a> for further details.	

## » Troubleshooting

Fault	Probable Cause	Solution
Water changes color or becomes cloudy.	<p>Rower is in direct sunlight or has not had water treatment.</p> <p>Local tap water is of poor quality.</p>	Change rower location to reduce direct exposure to sunlight. Add water treatment or change tank water as directed in the water treatment section of this manual. Consider using distilled water to refill tank.
Rower Belt slipping off belt/ bungee pulley.	<p>Bungee not under enough tension.</p> <p>Recoil not strong enough</p>	Tighten bungee cord following the instructions in "reattaching the rower belt" section of this manual.
Inconsistent readings on the Rower Computer for 500meter split time and SPM (strokes per minute).	<p>Sensor gap</p> <p>Faulty Sensor</p> <p>Sensor has moved out of position</p> <p>Wiring harness</p>	<p>Use the back cover of the computer as a "Gap tool" to check the gap between sensor head and Magnetic ring, or see if the Sensor head has moved out of position.</p> <p>Please contact your nearest FDF customer service center for details</p>
The Rower Computer does not illuminate after battery installation.	Batteries installed incorrectly or need replacing.	Replace/reinstall batteries in correct position and try again. If the LCD screen fails to illuminate, try rotating the batteries slightly in the computer. If this fails, contact your local service center.
The Rower Computer screen illuminates, but does not register when rowing.	<p>Loose or failed connection.</p> <p>Sensor gap too wide</p>	Check that the computer lead is connected properly. If it is connected then contact your local service center. Check Sensor gap.

# Optional Fixture Kit Instructions

A fixture kit for upright storage can be purchased separately.

## STEP 1

Install the Z bracket onto the Storage Base.

Note: Do not tighten the Knob and the Bolt.

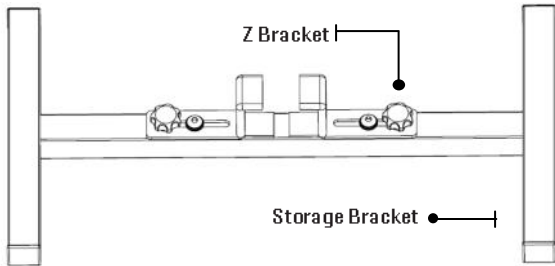

## STEP 2

Install the bracket onto the rower as shown.

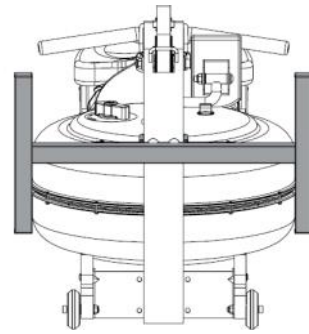

## STEP 3

Tighten the Z Bracket knob to fix to the rower.

Note: Ensure the Z bracket is secure before tightening.

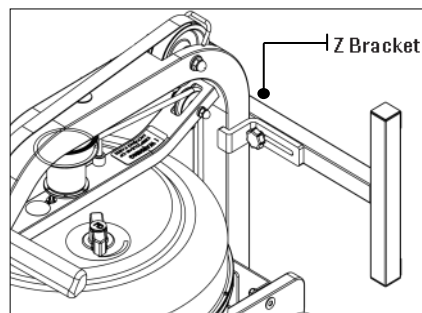
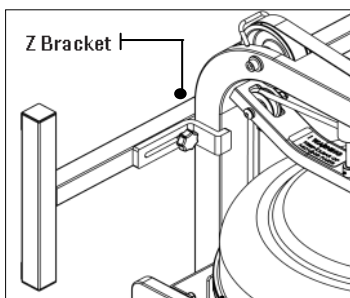

## STEP 4

Stand the rower up vertically with the main frame on the floor. Using the 8mm Allen Wrench tighten the Bolts.

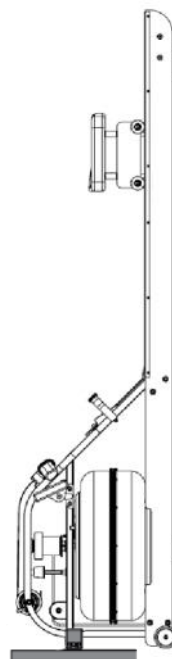

# Product Exploded Diagram

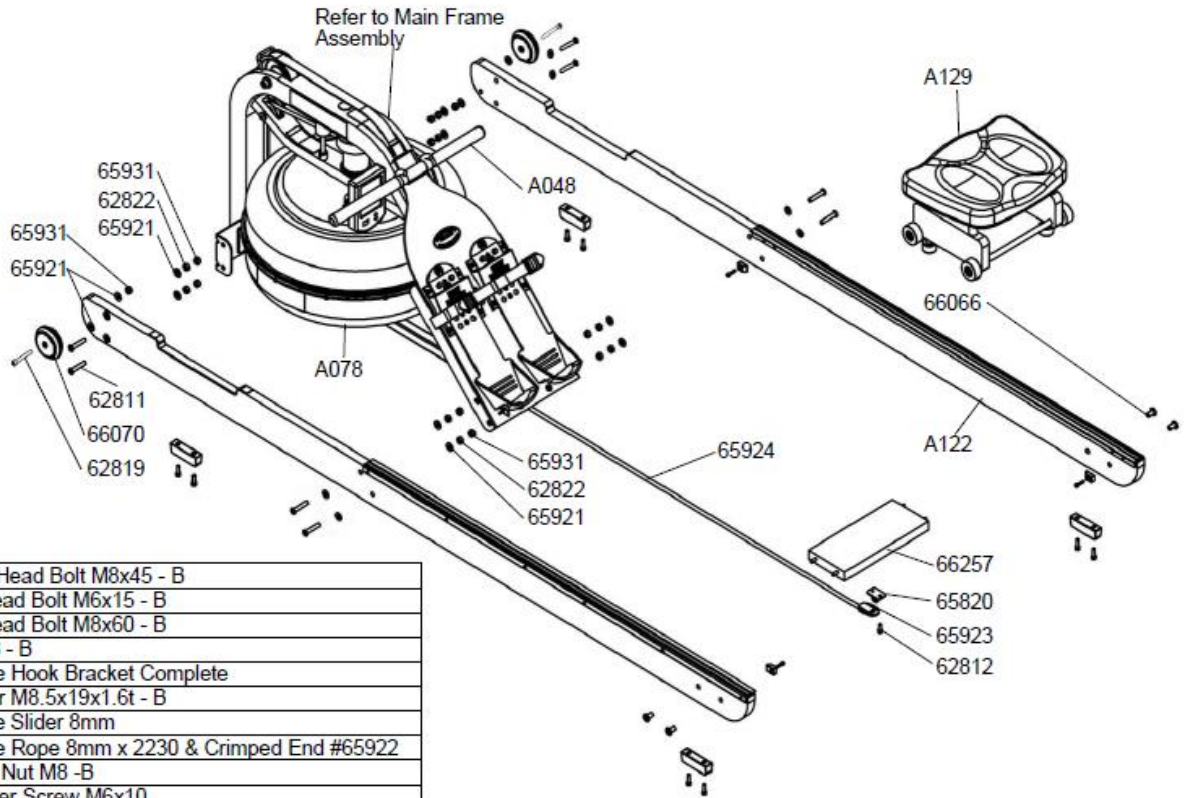

62811	8	Dome Head Bolt M8x45 - B
62812	1	Hex Head Bolt M6x15 - B
62819	2	Hex Head Bolt M8x60 - B
62822	8	Nut M8 - B
65820	1	Bungee Hook Bracket Complete
65921	20	Washer M8.5x19x1.6t - B
65923	1	Bungee Slider 8mm
65924	1	Bungee Rope 8mm x 2230 & Crimped End #65922
65931	10	Nylock Nut M8 -B
66066	4	Shoulder Screw M6x10
66070	2	Transport Wheel
66257	1	Rear Board -268x115x23 - Apollo AR
A048	1	Handle Complete - PACAR / Apollo AR
A078	1	AR Tank Complete Assembly
A122	1	Side Rail Complete Assembly L/R - Apollo AR
A129	1	Seat Assembly Copmplete

## Main Frame Assembly

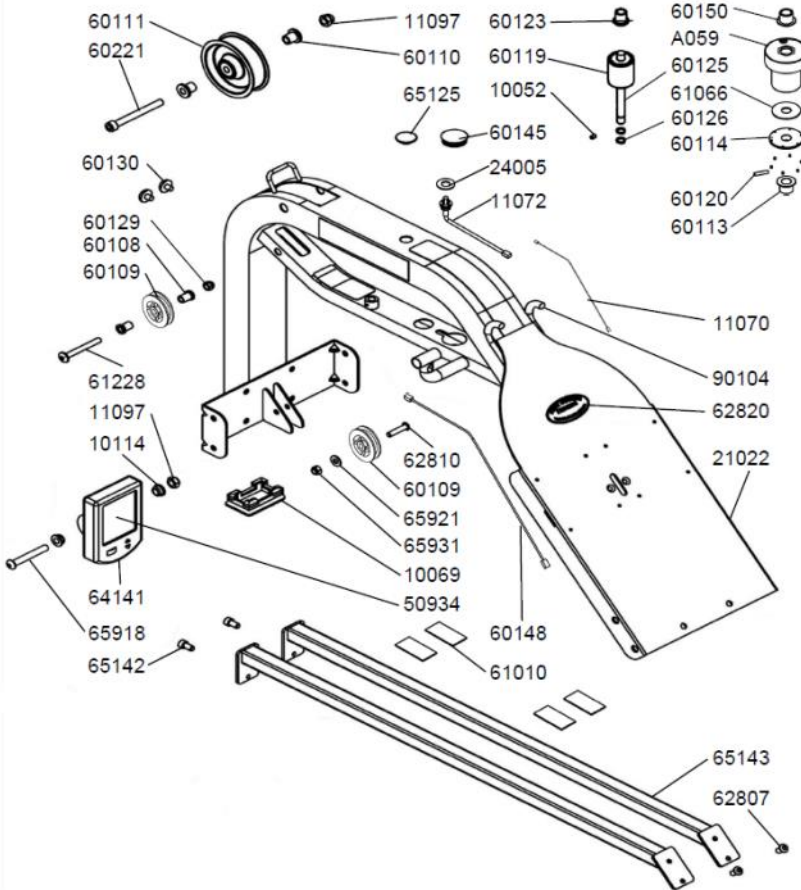

10052	1	Grub Screw M4x6 - B
10069	1	End Cap 75x50mm
10114	2	Computer Mount Plastic Bushing 20x16x13x10
11070	1	Sensor Connecting Cable 300mm
11072	1	Sensor 100mm
11097	2	Nut Dome Head M10 - B
21022	1	Upper Frame with Decal - Apello AR
24005	1	Washer M11x22x1t SUS
50934	1	LCD for L4/L16
60108	2	Bungee Pulley Spacer 8mm
60109	2	Bungee Pulley 50mm
60110	2	Belt Pulley Spacer 10x24x23
60111	1	Belt Pulley 100mm & 2x Bearing #60112
60113	1	Main Shaft Oil Bushing - Lower 38x20x22
60114	1	Magnet Ring & 6 x Magnet #60124
60119	1	Idle wheel & 2x Bearing #60112
60120	1	Roll Pin M6x30
60123	1	Idle Shaft Upper Frame Mount 10mm
60125	1	Idler Pulley Shaft
60126	2	C Clip 10mm
60129	1	Nut Dome Head M8 -B
60130	2	Frame Rubber Bumper
60145	1	Frame Plug 38.1mm
60148	1	Heart Rate Lead- 400mm
60150	1	Main Shaft Nylon Bushing - Upper
60221	1	Hex Head Bolt M10x90-B
61010	4	Tank Bonding Strip 3M-VHB 20x40mm
61066	1	Plastic Washer M5920.1x2T
61228	1	Dome Head Bolt M8x65 - B
62807	2	Dome Head Bolt M8x15 - B
62810	1	Dome Head Bolt M8x35 - B
62820	1	Oval Decal - FDF
64141	1	Computer with USB - L4
65125	1	Rubber End Cap - Main Frame
65142	2	Hex Head Bolt M8x15 -B
65143	2	Tank Strut
65918	1	Dome Head Bolt M10x60 -B
65921	1	Washer M8x19x1.6- B
65931	1	Nylock Nut M8 -B
90104	2	Rubber Hook Cover
A059		Belt/ Bungee Pulley Complete with Bungee Assembly

# Product Exploded Diagram

## A078—AR Tank Complete Assembly

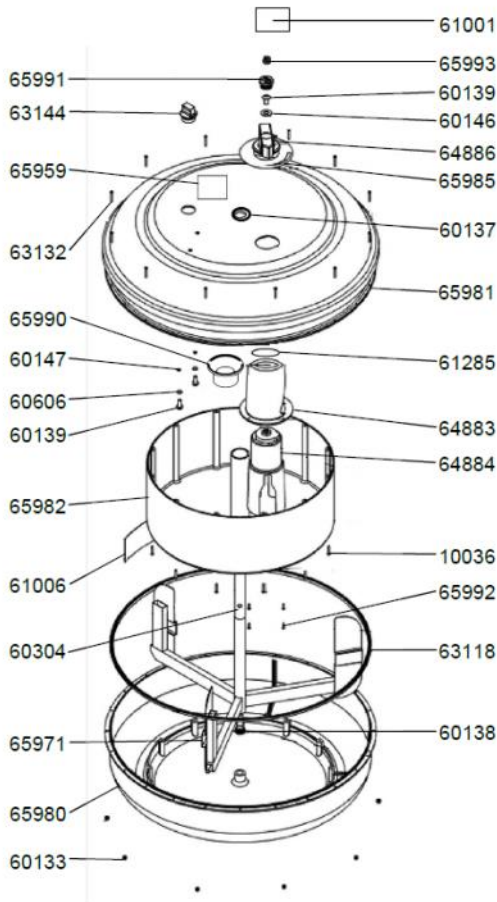

10036	12	Counter Sink Tapping Screw M3x20-SUS
60133	12	Nylock Nut M3-SUS
60137	2	Tank / Main Frame Impeller Shaft Spacer 19.9x40x1
60138	1	Impeller End Cap
60139	3	Dome Head Bolt M6x15-SUS
60146	1	Washer M6x16x1-SUS
60147	2	O- Ring 9.5x6.5x1.5
60304	1	Flywheel Upper Shaft
60606	2	Plastic Washer M6x15x2.5-B
61001	1	Tank Bonding Strip 3M 40x40mm
61006	1	Decal - HS Tank Level
61285	1	Rubber Spacer
63118	1	Tank Large Ring Seal -YELLOW 499x5.8
63132	12	Allen Key Bolt M3x20-SUS
63144	1	Tank Plug For HS Tank
64883	1	Tank Adjuster Outer Cup - 107C
64884	1	Tank Adjuster Inner Cup - 107C
64886	1	Adjuster Knob - 107C
65959	1	Decal - How to Adjust Resistance
65971	1	Impeller - AR
65980	1	Lower Tank Shell
65981	1	Upper Tank Shell & Decals & Spacer #60137 - Outer
65982	1	Inner Reserve Tank Shell
65985	1	Decal - AR Resistance
65990	1	Rubber Caldera
65991	1	End Cap - Adjust Knob
65992	4	Counter Sink Bolt M3x12-SUS
65993	1	Decal- FD Knob 18mm

## Sliding Footplate Assembly

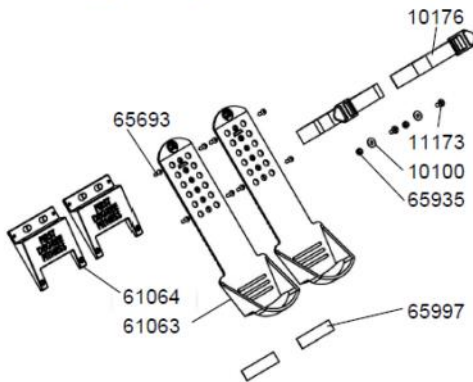

10100	2	Washer M6x16x1 -B
10176	2	Foot Strap & Buckle
11173	2	Counter Sunk Bolt M6x15 - B
61063	2	Footplate Slider with Velcro #65997
61064	2	Footplate Slider Base 120x111x22.8
65693	8	Dome Head Bolt M5x15 - B
65935	2	Nylock Nut M6 -B
65997	2	Velcro For Sliding Footplate

## A048 Handle Complete

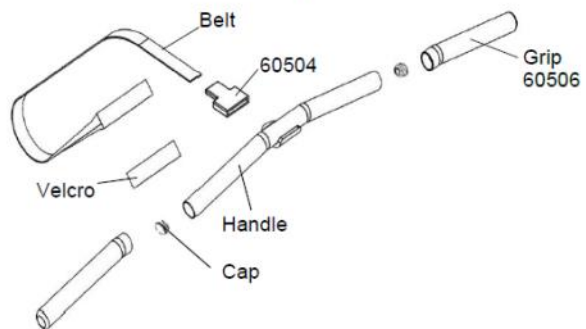

60504	1	Handle/Belt Rubber Cover
60506	2	Handle Grip

## A059 Belt Bungee Pulley Complete

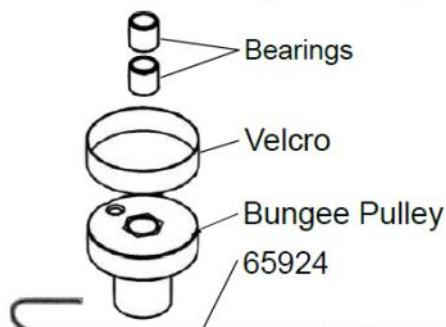

60900	1	Belt Bungee Pulley Complete & Velcro & One Way Bearings #90136
65924	1	Bungee 8mm x 2230 & Crimped End



# Product Exploded Diagram

## A129 Seat Assembly Complete

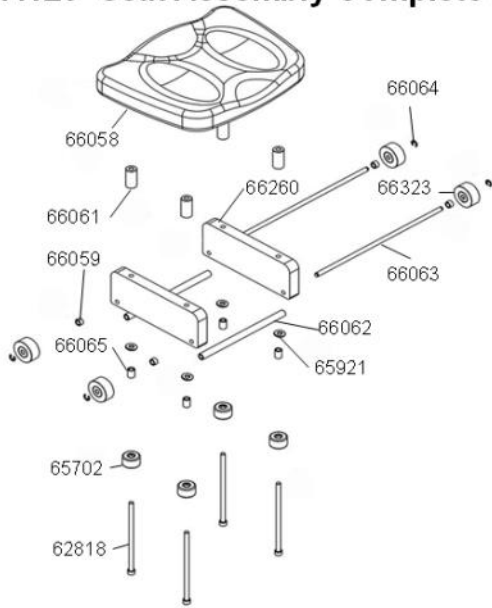

62818	4	Hex Head Bolt M8x160 - B
65702	4	Seat Wheel
65921	4	Washer 8.5x19x1.6t - B
66058	1	Seat LS-E28 - For Wooden Rail
66059	4	Spacer 12.7x8x8.5
66061	4	Spacer 20x8x40
66062	2	Spacer 12x8x209
66063	2	Axle shaft 8mm
66064	4	D7 Eclip
66065	4	Spacer 12.7x8x19.5
66260	2	Seat Frame - Apollo AR
66323	4	Seat Wheel 98A

## A122 Side Rail Assembly L/R

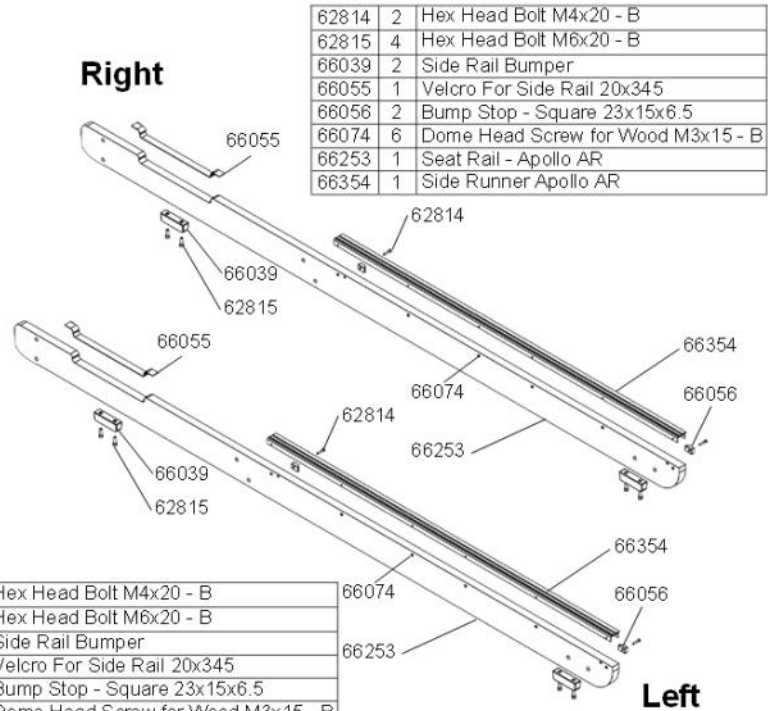

62814	2	Hex Head Bolt M4x20 - B
62815	4	Hex Head Bolt M6x20 - B
66039	2	Side Rail Bumper
66055	1	Velcro For Side Rail 20x345
66056	2	Bump Stop - Square 23x15x6.5
66074	6	Dome Head Screw for Wood M3x15 - B
66253	1	Seat Rail - Apollo AR
66354	1	Side Runner Apollo AR

62814	2	Hex Head Bolt M4x20 - B
62815	4	Hex Head Bolt M6x20 - B
66039	2	Side Rail Bumper
66055	1	Velcro For Side Rail 20x345
66056	2	Bump Stop - Square 23x15x6.5
66074	6	Dome Head Screw for Wood M3x15 - B
66253	1	Seat Rail - Apollo AR
66354	1	Side Runner Apollo AR

## A149 Seat Assembly Complete Black

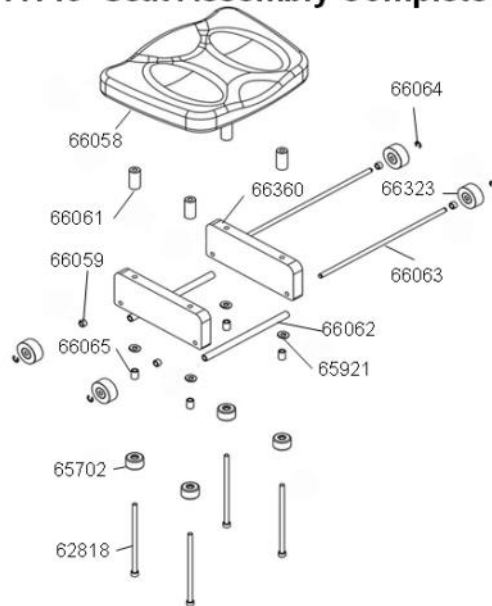

62818	4	Hex Head Bolt M8x160 - B
65702	4	Seat Wheel
65921	4	Washer 8.5x19x1.6t - B
66058	1	Seat LS-E28 - For Wooden Rail
66059	4	Spacer 12.7x8x8.5
66061	4	Spacer 20x8x40
66062	2	Spacer 12x8x209
66063	2	Axle shaft 8mm
66064	4	D7 Eclip
66065	4	Spacer 12.7x8x19.5
66360	2	Seat Frame Apollo AR Black
66323	4	Seat Wheel 98A

## A150 Side Rail Assembly L/R Apollo Black

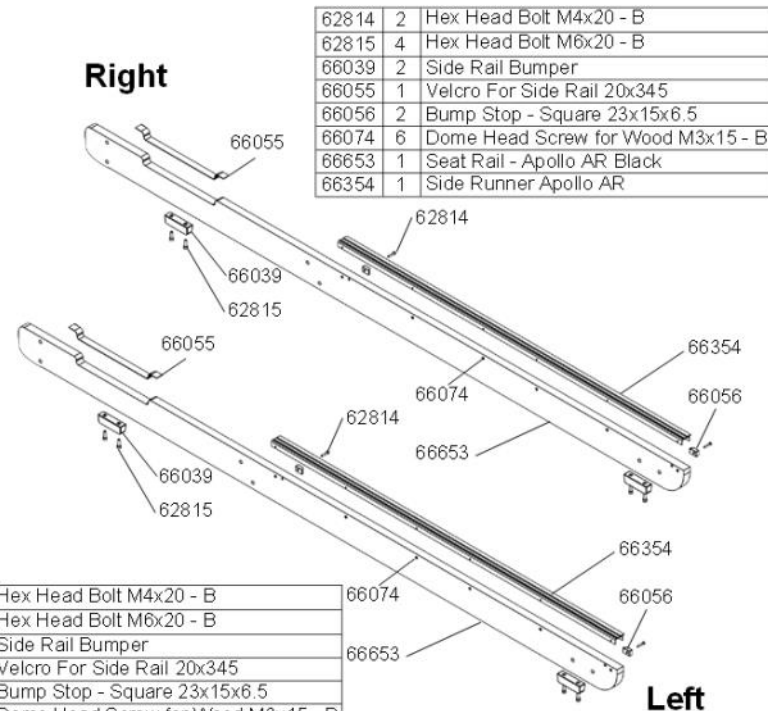

62814	2	Hex Head Bolt M4x20 - B
62815	4	Hex Head Bolt M6x20 - B
66039	2	Side Rail Bumper
66055	1	Velcro For Side Rail 20x345
66056	2	Bump Stop - Square 23x15x6.5
66074	6	Dome Head Screw for Wood M3x15 - B
66653	1	Seat Rail - Apollo AR Black
66354	1	Side Runner Apollo AR

62814	2	Hex Head Bolt M4x20 - B
62815	4	Hex Head Bolt M6x20 - B
66039	2	Side Rail Bumper
66055	1	Velcro For Side Rail 20x345
66056	2	Bump Stop - Square 23x15x6.5
66074	6	Dome Head Screw for Wood M3x15 - B
66653	1	Seat Rail - Apollo AR Black
66354	1	Side Runner Apollo AR

## HOME USE

FIRST DEGREE FITNESS Limited warrants that the **Apollo Hybrid AR (model HYBAR)**, purchased from an authorized agent and in its undamaged original packaging, is free from defects in materials and workmanship. FIRST DEGREE FITNESS Limited or its agent will, at their discretion, repair or replace parts that become defective within the warranty period, subject to the specific inclusions and exclusions below.

### **Main Frame – 5 Year Limited Warranty**

FIRST DEGREE FITNESS will repair or replace the Metal Frame of the Rower should it fail due to any defect in materials or workmanship within 5 years of the original purchase. Warranty does not apply to frame coating.

### **Polycarbonate Tank & Seals – 3 Year Limited Warranty**

FIRST DEGREE FITNESS will repair or replace the polycarbonate tank or seals should they fail due to any defect in materials or workmanship within 3 years of the original purchase.

### **Mechanical Components (of a non-wearing nature) – 2 Year Limited Warranty**

FIRST DEGREE FITNESS will repair or replace any mechanical component should it fail due to any defect in materials or workmanship within 2 years of the original purchase.

#### **Specific Inclusions**

Seat Frames  
Stainless Steel Impeller Assembly

### **All Other Components (of a wearing nature) – 1 Year Limited Warranty**

FIRST DEGREE FITNESS will repair or replace any component should it fail due to any defect in materials or workmanship within 1 year of the original purchase.

#### **Specific Inclusions**

Bungee Recoil Cord  
Hand Grips & Foot Straps  
Polyester Rowing Belt  
Seat and Seat Runners  
All pulleys, rollers & bearings  
All rubber components  
Computer & speed sensor (excluding replaceable batteries)  
Footplates (pivoting & sliding)

#### **General Exclusions**

Damage to the finish of any part of the machine  
Damage due to neglect, abuse, incorrect assembly or use of the machine  
Any charges for freight or customs clearance associated with the return or dispatch of parts  
Any damage to or loss of goods during transport of any kind  
Any labour cost associated with a warranty claim

#### **General Conditions**

- The serial number of the machine must be correctly registered with FIRST DEGREE FITNESS Limited or one of its appointed distributors
- FIRST DEGREE FITNESS Limited reserve the right to examine any part where replacement is claimed under warranty
- Warranty period applies only to the original purchaser from the date of purchase and is not transferable
- The product must be returned to your place of purchase in original packaging with transportation, insurance and associated charges paid for by you and risk of loss or damage assumed by you
- FIRST DEGREE FITNESS makes no other warranties except as stated here and expressly disclaims all warranties not stated in this warranty. Neither FIRST DEGREE FITNESS nor its associates shall be responsible for incidental or consequential damages
- Manufacturer's warranty automatically commences upon sale of the product to end user or upon the expiration of one (1) year from month of manufacture, whichever occurs first





FIRST DEGREE FITNESS  
*Fluid* INNOVATION

FITNESS PRODUCTS INSPIRED BY REAL LIFE

[WWW.FIRSTDEGREEFITNESS.COM](http://WWW.FIRSTDEGREEFITNESS.COM)

CONTACT US

For customer support please visit  
[firstdegreefitness.com/support](http://firstdegreefitness.com/support)

TAIWAN

T: +886 3 478 3306  
764 Chung Shan South Rd  
Yangmei Taoyuan  
Taiwan R.O.C.

